

VestAlAire CIRCULATOR FIREPLACE

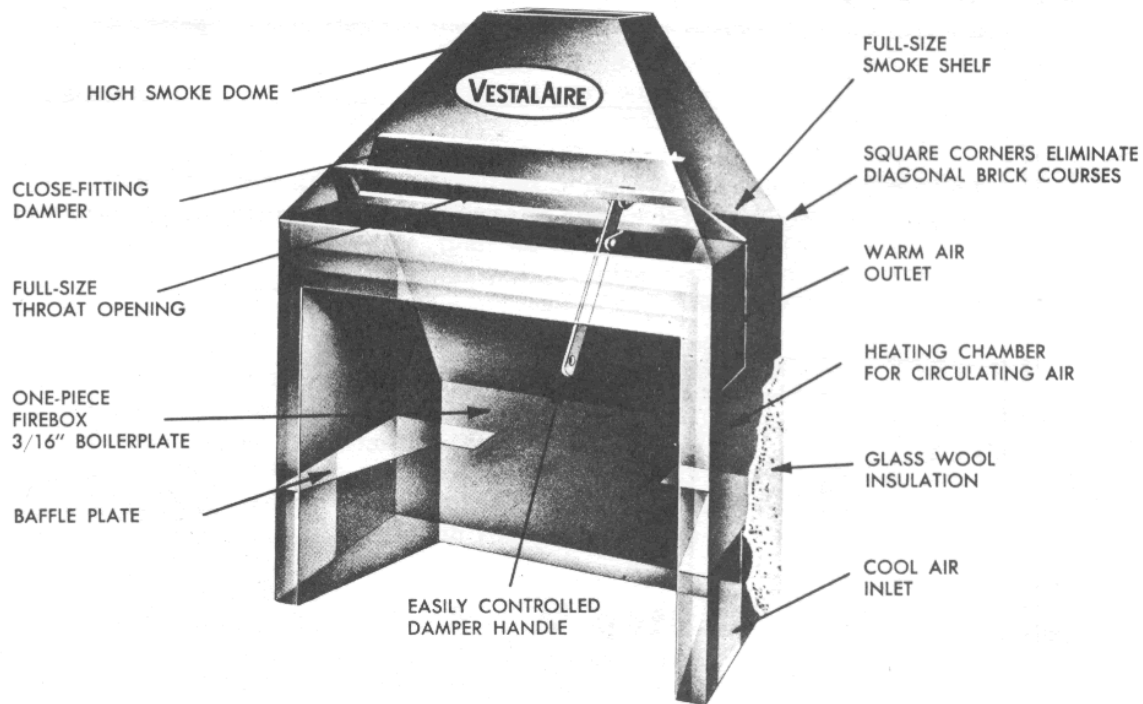

Important Installation Instructions for Mason or Builder

These instructions are written to be used by an experienced mason or builder who is familiar with applicable codes concerning the construction of masonry fireplaces.

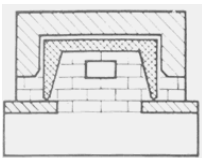

Fig 1: Hearth Plan at Floor Level

Step 1: Finish the foundation with a layer of firebrick upon which to set the Circulator Unit. The firebrick should extend beyond the Circulator at the sides and back and be at least flush with the front of the Circulator. If the fireplace is to have an ash pit, the ash dump should be put in at the time of the firebrick base is laid. Do not lay firebrick up into the metal firebox of the Circulator. (See Figure 1.)



Step 2: Position the Circulator on the firebrick hearth. Unpack glass wool insulation and apply around the bottom of the unit. Cover the unit with a single thickness of insulation, taking particular care at corners. A thin watery mixture of mortar brushed on the steel Circulator will help to hold the insulation in place. At this point if particular care is given to the glass wool insulation, location of the cold air intake grille, and gauging of the masonry work, the rest of the installation will be made much easier. (See Figure 2.)

Fig 2: Unit in Position

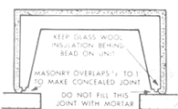

Fig 3: Insulation & Concealed Joint

Step 3: Lay the first course of masonry dry around the unit to check dimensions, thickness of mortar joints and grille locations. Take care to prevent the masonry from touching the unit at any point. The finished width of the fireplace opening should be 1" to 2" less than the width of the Circulator opening. Lay the masonry beyond the Circulator on each side of the Circulator opening, making a concealed joint between the Circulator and the masonry. Due to heat expansion, mortar will not stay in this concealed joint. (See Figure 3.)

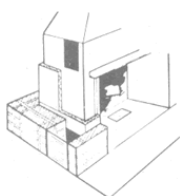

Fig 4: Brick Work & Grille Location

Step 4: Plan the location of the cold air intake grilles. Air must not pass direct from the cold air inlet to the hot air outlet. The air must be circulated through the unit. Air passages should be finished smoothly to speed air flow and prevent heat loss.

The "VestAlaire Universal Grille and Duct" system will simplify planning and installation of air intakes and outlets. If electric fan grilles are to be used in the Circulator, and the power line to the fan is concealed, it may be desirable to locate the conduit and junction box in the masonry. When fans are used, two fans—one located in each cold air intake—are needed. Never locate the fans in the warm air outlet. Set the cold air intake grilles in place. Do not remove top grille face until the boxes are installed in the masonry. This assures a neat and level

fit and protects the grilles. After dimensions are checked, the location of the grille and thickness of the mortar joints determined, the dry course of brick can be taken up and laid permanent with mortar. (See Figure 4.)

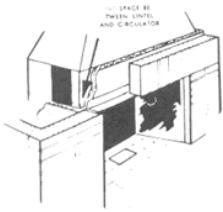

Fig. 5: Setting the lintel

Step 5: With this start, proceed with the masonry in the regular way. Keep in mind:

1. Glass wool insulation around the Circulator Unit.
2. The concealed joint at fireplace opening.
3. The cold air intake and warm air outlets must be planned for and located in the masonry and must be separated by masonry or ducts.
4. All weight of the chimney must be supported by the masonry and not on the Circulator Unit.
5. When the top of the fireplace opening is reached, use a metal lintel of adequate strength to support the masonry work above. Set the lintel low enough to conceal the metal apron of the Circulator Unit. Pack loosely generous quantities of insulation behind and at the end of the lintel. (See Figure 5).

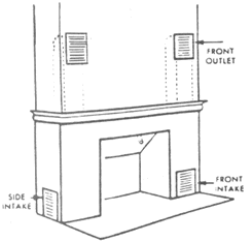

Fig. 6: Air Outlets may be above mantel

Step 6: Plan the location of the warm air outlet grille in the same manner as the cold air intake. The outlet grille must be a minimum of 6" below the ceiling or mantel or any projecting combustible surface. For projecting or corner installations the side of the grille must be a minimum of 6" from a combustible wall. The outlet grille must be mounted with the louvres pointed down. A combustible mantel must be at least 32" above the fireplace opening.

Step 7: When the face of the fireplace has been built up to desired height, start corbelling the masonry back to meet the dome of the smoke chamber and the flue lining. Be sure the smoke chamber is covered with insulation. See that tight connection is made to the flue lining and that plenty of insulation is packed loosely around the place where the flue lining meets the smoke chamber. Do not allow the flue lining to rest on the Circulator; the lining must be supported by the chimney masonry. (See Figure 7.) Refer to NFPA 211 for proper masonry chimney construction and clearances.

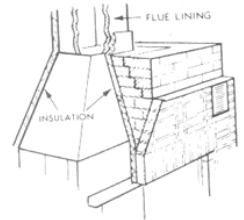

Fig. 7: Brick should be corbelled to support chimney

Step 8: Finish the chimney in the normal way. In some construction, the flue from other heating apparatus is incorporated in the same chimney. If this is the case, keep the flue well back into a corner so as not to interfere with the air intakes and warm air outlets.

If the chimney is close to trees, or high hills, a chimney hood or cap may be desirable to prevent downdrafts. If a chimney hood is used, the opening underneath the hood must be equal to, or preferably greater than, the total area of all flues incorporated in the chimney. (See Figure 8.) NOTE: Before leaving the job, try the damper to make sure it opens wide and closes tight. It may be necessary to clean out fallen mortar. Leave the valve plate wide open to circulate air up the chimney. This helps to cure the masonry. Do not build a fire in the fireplace for several days, allowing time for the masonry to cure thoroughly.



Fig. 8: Chimney may be hooded if desired.

Easily Controlled Damper

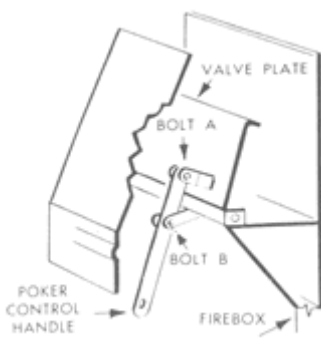

Fig. 9: Built-in damper operates easily

The poker control handle pulls forward to open the valve plate, back to close. The handle is designed to hold the valve plate securely in any desired position. Friction is made on the handle by tightening the grip nut at bolt "A." The poker control handle should move freely but with enough tension for positive positioning. Tension is correctly set at factory. During shipment, the nuts at bolt "A" and bolt "B" could possibly loosen and require readjustment.

If after years of usage it should become necessary to clean out the chimney flue and smoke shelf, the valve plate of the Vestal Circulator can be removed. Remove the poker control handle by taking loose bolts "A" and "B." Slide the valve plate to the left until it stops, then push the right end of the valve plate to the back of the unit until it is free of its hinges. Proceed to work the valve plate down through the throat opening. Due to oversize design of the valve plate it is a close fit, both the valve plate will come out by manipulating through the throat opening. The valve plate is replaced by reversing the above procedure. (See Figure 9)

Intake And Outlet Grilles

Openings in the masonry are skillfully hidden by the decorative grilles on the cool air intakes and warm air outlets of the Vestal Fireplace. They blend perfectly with any style mantel, and can be painted to match the surrounding walls or masonry. A metal housing is set permanently in the masonry or wall to which the grille face is attached.

Grilles suitable for use with any size Vestal Circulator Fireplace.

MODEL NO	DESCRIPTION	GRILLE SIZE	HOUSING SIZE
9	Stamped Steel	9 3/8" x 9 3/8"	7 7/8" x 7 7/8"
176	Cast Iron	7 1/4" x 9"	6 1/8" x 8"

Installing Grilles: The location of the grilles is dependent on choice and the amount of projection of the fireplace into the room. The grilles should be assembled before setting the housing in masonry so that the grille faces will be properly leveled. After masonry has set, grille faces can be removed to finish air passages. If air inlets or outlets are formed of masonry, the brick must not exceed 1 1/4" thick and be spaced 1 x 1/2" apart. Inlets must total 36 square inches each. Outlet or outlets must total 72 square inches.

Electric Fans

By using fans at the intake openings, the heating capacity of the Vestal unit can be considerably increased. Fans should be installed at both cold air intakes for maximum efficiency.

VESTAL Circulating Fireplaces Operating Instructions:

Inspection, Maintenance and Cleaning of Chimney:

Before the first fire, the chimney should be inspected for cracks and voids in the flue liner and all loose mortar should be removed from the top of the circulator smoke shelf. Make sure that the damper moves to both full open and closed positions. A removable flue cap should be installed to protect the circulator from moisture and rust. The smoke shelf can be cleaned by removing the damper handle and letting the damper door lay back on the smoke shelf. When needed, the chimney can be cleaned by using a flue brush from the top of the chimney. The loosened material can then be removed from the smoke shelf. A canister type vacuum cleaner is very helpful for this.

Creosote—formation and need for removal:

When wood is burned slowly, it produces tar and other organic vapors, which combine with expelled moisture to form creosote. The creosote vapors condense in the relatively cool chimney flue of a slow burning fire. As a result, creosote residue accumulates on the flue lining. When ignited this creosote makes an extremely hot fire. If creosote has accumulated it should be removed to reduce risk of a chimney fire.

Operation:

Fire may be built directly on the hearth of the fireplace, or andirons or grates may be used. Place a medium to large piece of wood in the back of the firebox. In front of the back log place one to two pieces of crumpled newspaper and about two handfuls of finely split kindling. Soft woods work best for this. Ignite the paper. After the kindling has started to burn, add two to three pieces of large wood. After these have started to burn down into coals add one or two larger pieces of wood at a time until the desired size of fire is reached. The fire is maintained and controlled by the amount and size of the wood used. Always use dry, seasoned wood. Do not leave fire unattended unless a firescreen is in place to prevent sparks from popping into the room. Do not overfire. Overfiring is usually caused by adding too much wood at one time. Use solid fuel only. Do not set furniture or other combustible items within four feet of the fireplace front.

Caution:

"Never use gasoline, gasoline-type lantern fuel, kerosene, charcoal lighter fluid, or similar liquids to start or freshen up a fire in the fireplace. Keep all such liquids well away from the fireplace while it is in use."

Disposal Of Ashes:

Ashes should be placed in a metal container with a tight-fitting lid. The closed container of ashes should be placed on a noncombustible floor or on the ground, well away from all combustible materials, pending final disposal. If the ashes are disposed of by burial in soil or otherwise locally dispersed, they should be retained in the closed container until all cinders have thoroughly cooled.

Installation Instructions for VESTAL Circulator Fireplace

General: The mason is urged to read these instructions carefully. Frequent reference to these instructions and drawings will help the mason to do a perfect job of installing the Circulator Unit. Particular attention should be given to the application of the glass wool insulation. The Circulator Unit must not be used as a support for the masonry. The masonry at all points must be self-supporting. Keep masonry 1/2" to 1" away from the steel at all points to allow for normal heat expansion. See that any mortar squeezed from the mortar joints does not touch the unit at any point.

Foundation: Foundation dimensions will vary with the size of the Circulator used—type of masonry (brick or stone)—number and size of any other flues in the same chimney—and width of fireplace on each side of the fireplace opening. Therefore, due to the unlimited variety of applications for the Vestal Circulator Fireplace Unit, it is impossible to give specific details that cover all installations and dimensions of the foundation.

The foundation is to be constructed of concrete or solid masonry and generally should be at least 12" thick and extend beyond the masonry walls 6" on all sides unless codes or conditions call for greater thickness and/or extension.

UNIT SIZES

Model No.	Finished Opening		Fuel Capacity	Shipping Weight
	Width	Height		
30	28"	24"	Up to 24"	195
34	32"	26"	Up to 28"	237
38	36"	28"	Up to 32"	275
42	40"	28"	Up to 36"	335
50	48"	28"	Up to 42"	420

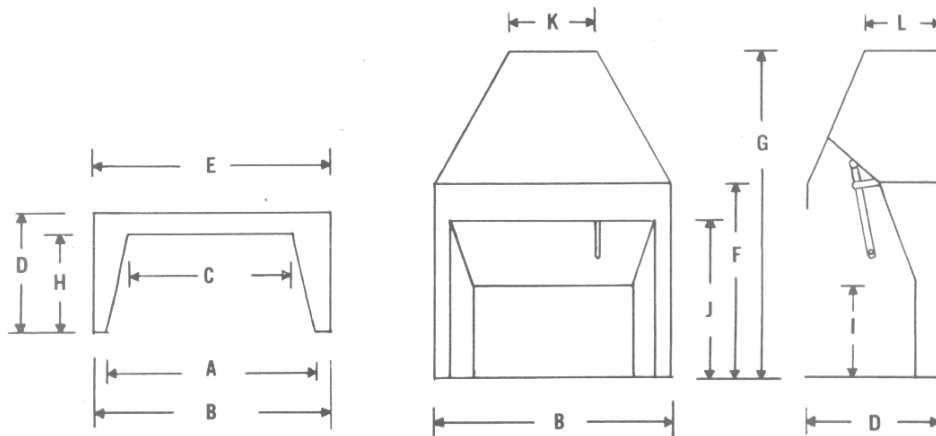

UNIT DIMENSIONS IN INCHES

MODEL	A	B	C	D	E	F	G	H	I	J	K	L
30	30	34	22 1/4	18 1/2	34	30	46 1/4	15 1/4	14	25	11 3/4	7 3/4
34	34	38	24 1/4	19 3/4	38	32	49 3/4	16 1/2	14	27	11 1/2	11 1/2
38	38	42	28 1/4	21 1/4	42	35	53 3/4	17 1/2	16	29 1/4	11 1/2	11 1/2
42	42	47	31 1/4	23 1/4	47	38	58 1/4	19 1/4	16	32	16 1/2	11 1/2
50	50	56	39 1/4	25 1/4	56	40 1/4	62 3/4	20 1/4	17	34	16 1/2	11 1/2

CHIMNEY FLUE SIZES

MODEL NO.	FOR CHIMNEYS OVER 20' HIGH			FOR CHIMNEYS 16' TO 20' HIGH		
	STANDARD FLUE	MODULAR FLUE	ROUND FLUE	STANDARD FLUE	MODULAR FLUE	ROUND FLUE
30	8 1/2" x 13"	12" x 12"	10"	8 1/2" x 13"	12" x 12"	10"
34	8 1/2" x 13"	12" x 12"	10"	13" x 13"	12" x 16"	12"
38	13" x 13"	12" x 16"	12"	13" x 13"	12" x 16"	12"
42	13" x 13"	12" x 16"	12"	13" x 18"	16" x 16"	15"
50	13" x 18"	16" x 16"	15"	13" x 18"	16" x 20"	15"

Outside dimensions shown for standard and modular flues – inside dimensions for round flues. Chimney height is measured from hearth.

NOTE: Dimensions shown are actual measurements. Be sure to allow 1/2" to 1" space for glass wool insulation for heat expansion between all points of the Circulator and the masonry.

TYPICAL CONSTRUCTION DETAIL

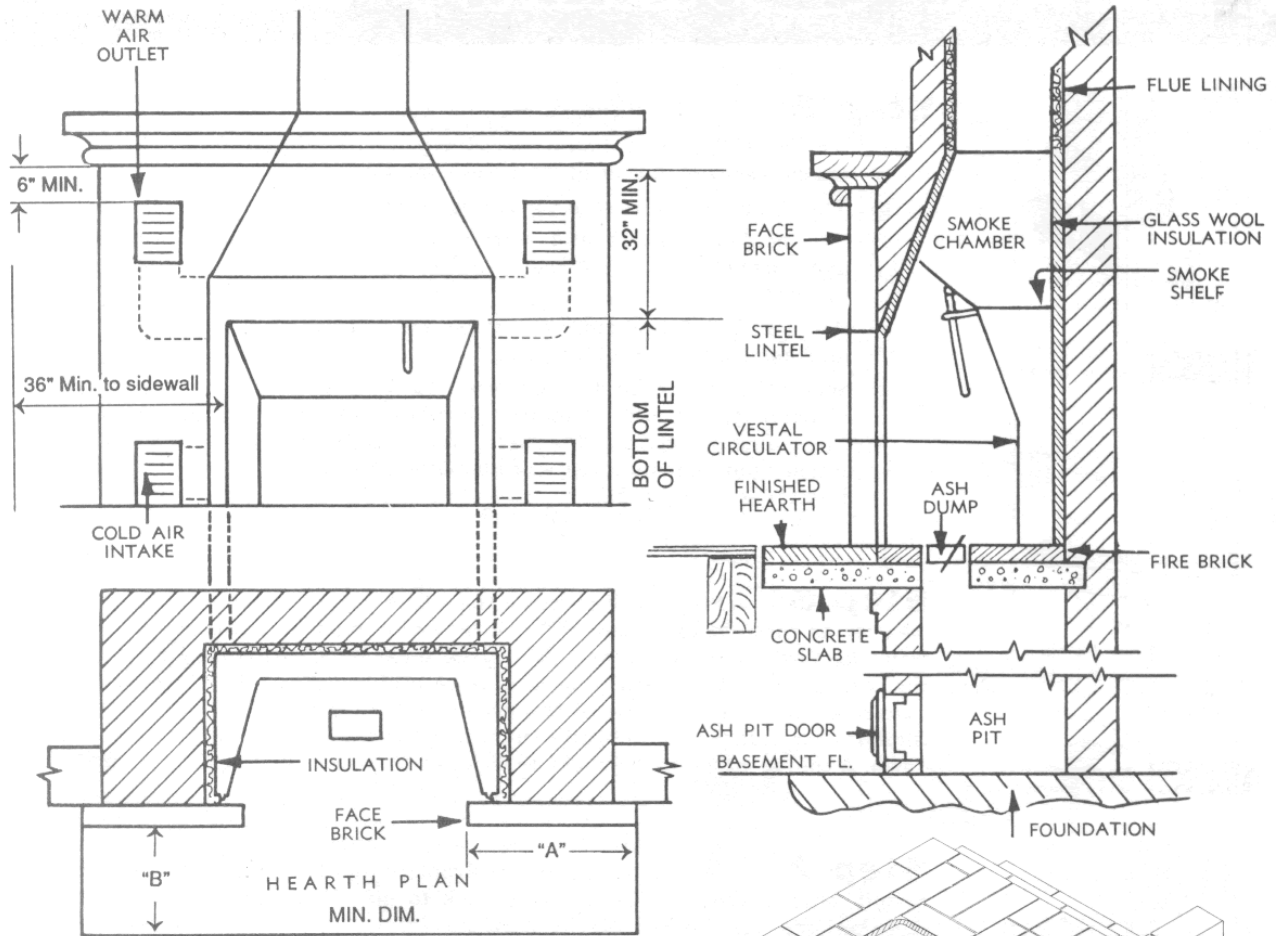

MODEL	A	B
30	8	16
34	8	16
38	12	20
42	12	20
50	12	20

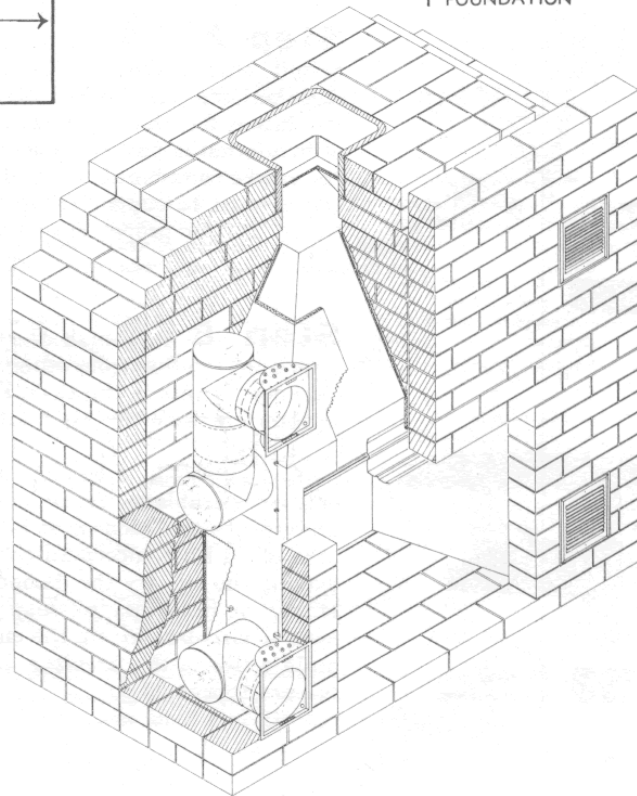

Consult applicable building codes concerning the construction of masonry fireplaces.

Air passage must be provided through this circulator. Failure to do so will void the warranty and damage the unit as well as possibly create a fire hazard. This is not a zero clearance fireplace. It must be installed within a masonry fireplace and chimney structure that meets applicable codes.

Source: Vestal Manufacturing, PO Box 420 Sweetwater, Tennessee 37874